

VISION

# Blue 1011 i, b

i - injection | b - boiler



## UNIQUE BENEFITS



### Vision Perfect Cooking

Make your diners great reason to keep returning to your place. With Retigo Vision combi ovens, you have the peace of mind that you will always achieve outstanding cooking results. The prepared foods have a perfect colour, are juicy, crispy and healthy with a minimal fat content.



### Vision Design

Simply keeps you cooking with ease and comfort. Experience an excellent combination of features, exceptional ergonomics and attractive appearance. All this with a focus on safety, hygiene and long time reliability.



### My Vision Controls

Gives you time to concentrate on cooking and things that really matter to you. The simplest controls on the market will save you time and enable you to quickly and easily make all the necessary settings. Display response is perfect even with grease or gloved hands. Adapt the main menu to your needs.



### Smart Investment

Generates money on savings for you every day. In-built heat exchanger, tripple glazed door glass, 50 mm thick thermoinsulation combined with low consumption automatic cleaning will ensure you great return on investment.

# FEATURES & BENEFITS

## Cooking

- **Hot air** 30 – 300 °C
- **Combination** 30 – 300 °C
- **Steaming** 30 – 130 °C
- **Bio steaming** 30 – 98 °C
- **Over night cooking** – Saves time and money.
- **Rack timing** – Set individual rack times for multi product cooking.
- **AHC (Active Humidity Control)** – Automatic humidity control for great cooking results.
- **Advanced steam generation system** – Two-step water preheating with in-built heat exchanger for perfect steam cooking results.
- **Crosswise racks** – Safer and comfortable GN handling. Better product visual control.
- **Regeneration/banqueting** – Cook, chill and regenerate to serve more diners in shorter times.
- **Delta T cooking** – Use advanced cooking method to reduce shrinkage on slow roasted meats getting amazing results.
- **Low temperature cooking** – Benefit from less weight loss, better taste.
- **Cook & Hold** – Let it cook and held serving temperature.
- **Golden Touch** – Add a golden-brown, crispy finish with just a touch.
- **Automatic preheating/cooling** minimises the loading temperature drop. Start cooking with the desired temperature.
- **Sous-vide, Drying, Sterilization, Confit, Smoking** – Great way to make your menu special.

## My Vision Controls

- **8" display** – Perfect overview, easy and intuitive control.
- **MyVision** – Customize your menu so you have all you need right on the main screen.
- **Touch panel** – Panel works under all conditions and has a fast response, no mechanical elements, buttons or wheels.
- **Easy Cooking** – Get great results even with less experienced chefs thanks to easy cooking guidance.
- **6-point core probe** – Allows foods to be automatically cooked to any desired internal temperature.
- **1000 programs with 20 steps**
- **Pictograms** – Take a food picture on the main screen. Match it with a program. Touch it to get the desired cooking results repeatedly.
- **Learn function** – All cooking adjustments are recorded. At the end you save great results achieved and recall them again when needed.
- **Last 10** – Cooking process easy to be used again by just a touch.
- **Multitasking** – Unique opportunity to work with a display during cooking.
- **Automatic start** – The ability to schedule a delayed start.
- **EcoLogic** – Energy consumption shown right on the screen. Keeps your cost under control.
- **Continuous cooking time option** - Saves your time during busy operations.

## Other equipment

- **Active Cleaning** – Low-cost automatic cleaning. No chef's time spent on cleaning any more.
- **Triple glazed door glass** - Advanced energy savings and external glass that does not burn you.
- **Auto-reversing fan** – Excellent evenness to deliver high product color and texture uniformity.
- **Flap valve** – Patented dehumidification system for great colour and crispiness.

\* for boiler combi ovens only

- **7 Fan speeds** – Precise control of air distribution for desired results with different products.
- **Automatic Fan stop** – No scalding when the door opened quickly.
- **Fan timing** – 3 steps for greater evenness and gentle cooking.
- **Massive door handle** – Comfortable and safe handling with silver ion material contain for bacteria reduction.
- **AISI 304 stainless steel** – Exceptional quality with a special coating for an extended life time.
- **Hygienic cooking chamber with round inner corners** – Trouble free maintenance.
- **Hand shower** – External water supply hose with spray nozzle. Extra water source at your disposal.
- **Run-off tray under the door** – No slipping on wet floor.
- **Two water inlets** – Saves a water treatment unit's capacity.
- **WSS (Water Saving System)** – Special drain system & in-built heat exchanger to save water related cost.
- **Removable GN holders** with 65 mm spacing

## Connectivity

- **USB plug-in** – Transfer useful data easily to and from the combi oven.
- **Ethernet/LAN** – Allows remote access for data management.
- **VisionCombi software** – Program and pictogram management in your PC, HACCP data view.

## Operation logs

- **HACCP records** – Easy and immediate analysis of critical cooking points.
- **Complete operating records**

## Service

- **BCS\* (Boiler Control System)** – Nothing stops you steam cooking with the in-built advance direct steam generation system.
- **SDS (Service Diagnostic System)** – Easy unit check up and trouble shooting.

## Unit options

- Left door
- Safety door opening in two steps
- Second temperature core probe
- Retractable hand shower
- Connection to the system for power consumption optimization

## Optional accessories

- ST 1116 stand with 16 x GN 1/1 racks
- ST 1116 FP flat pack stand with 8 x GN 1/1 racks
- ST 1116 CS stand ST1116 with wheels
- ST 1116 H stand with 16 x GN1/1 racks, height 900 mm
- STAND with place for Holdomat
- STAND with place for blast chiller BC411P or BC511P, C
- VISION VENT condensation hood
- GN ADAPTER for 2 x GN1/2 or 3 x GN1/3
- TRAY HOLDERS with spacing 85, 70 mm or with GN 400/600 racks
- VISION OIL GUN
- VISION SMOKER
- ACCESSORIES – Gastro containers, cleaning agents, water treatments

# TECHNICAL DATA

## STACKING OPTIONS

Lower unit	Upper unit	
		611
1011	yes	yes

## OPTIONAL VOLTAGE

Model	1011
3N~/230V/50Hz	yes
3PE~/440V/60Hz	yes

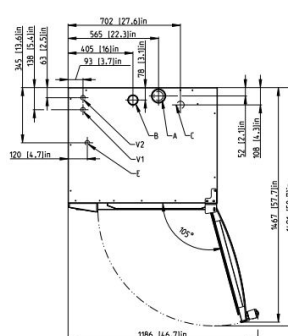
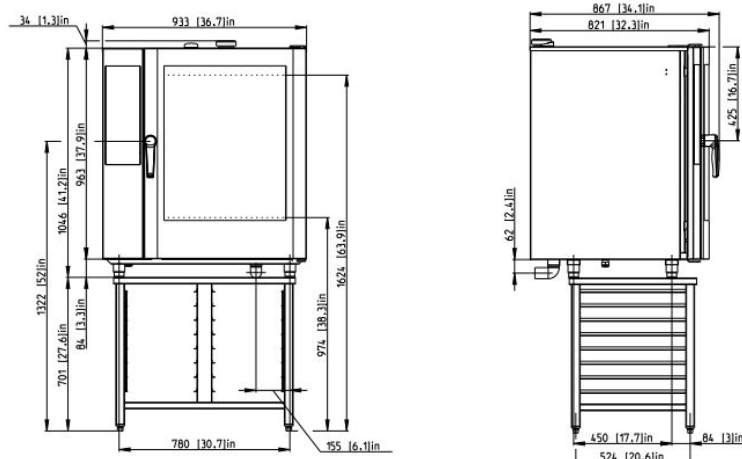

A	flap valve
B	chimney
C	waste
E	electricity
V1	untreated water
V2	treated water
Placed on ST 1116	

Model	B 1011 i	B 1011 b
Technical specification	2E1011IA	2E1011BA
Energy	Electricity	Electricity
Steam generator	Injection	Boiler
Capacity	11 x GN 1/1	11 x GN 1/1
Capacity (optional)	11 x 400/600	11 x 400/600
Capacity of meals	151 – 250	151 – 250
Spacing	65 mm	65 mm
Dimensions (w x h x d)	933 x 1080 x 818 mm	933 x 1080 x 818 mm
Weight	138 kg	144 kg
Total power	18,6 kW	18,6 kW
Heat power	18 kW	18 kW
Steam generator power	–	18 kW
Fuse protection	32 A	32 A
Voltage	3N~/400V/50-60 Hz	3N~/400V/50-60 Hz
Noise level	max. 70 dBA	max. 70 dBA
Water/Drain connection	G 3/4" / 50 mm	G 3/4" / 50 mm
Temperature	30 - 300 °C	30 - 300 °C